

# CORI-FORCE®

## MASSFLOW & DENSITY MEASURING SYSTEM

At the control of industrial processes an important task is the measurement and control of substance flows. The account of substance quantities is performed more and more frequently based on the supplied mass, the direct measurement of which allows higher accuracy by less maintenance needs than what could be achieved with traditional systems built of volume flow meter and density meter.

The **CORI-FORCE®** massflow measuring system, beside the highly accurate measurement of massflow, provides numerous utilities for the user. The system consists of a sensor of size depending on the measuring range and of the **C-MASS®** signal processing electronic unit.

The sensor can be operated in explosion hazardous area. In this case the electronic unit of the measuring system contains a zener barrier unit. The protection mode of the measuring system - depending on the construction of the sensor - is **[EEx ib] IIB, EEx ib IIB T3/T6** or **[EEx ib] IIB, EEx deib IIB T3/T6**.



### Specification

#### Sensor type selection

3 6 4 8 - 0 - B C D - E

	Sensor type	Max. flow (kg/h)
0	K 5	270
1	K 20	540
2	K 100	2700
3	K 250	6750
4	K 500 K 500s	13500
5	K 2500	40500
6	K 2600	60000
7	K 4000	100000
8	K 6000	160000

	Material
1	316L
3	Hastelloy C22

	Pressure (bar)
0	16
1	40
2	100
3	200

	Connection
0	flat
1	NPT external thread
2	ANSI loose flange
3	ANSI welded flange
4	DIN loose flange (up to 4 MPa)
5	DIN, welded flange (up to 16 MPa)
6	NPT inner thread
7	special
9	K-500S for tank-car

### Main features of the sensor

- Measured parameters of the fluid:
  - massflow
  - density
  - temperature.
- Materials of wetted parts: 316L and KO36Ti or Hastelloy C22.
- Temperature range of the fluid:
  - in non-Ex. area : -50...+200 °C
  - In Ex. area: -20...according to classification.
- Ambient temperature: -50 ... +70 °C.

- Three - separately programmable - internal resettable counters.
- Fraction menu for determining the composition of two component substance:
  - Determining the components of mixture
  - determining the amount of pure spirit in water solution of spirit
  - Net oil determination of crude oil.
- Two - separately programmable - current outputs of the measured values
- Programmable PID control.

### Galvanically isolated outputs and inputs

- remote zero start input (measuring system/resettable counters),
- batch control start input,
- limit error signaling output,
- error output (for limit and other errors),
- programmable outputs :
  - for signaling zeroing process or
  - fast batch control
  - signaling flow direction,
- Output for remote counter control,
- frequency output (of massflow or volume flow).

### Main features of the signal processing unit

#### C-MASS®

- More than hundred data and measured value accessible by the keypad or by serial line.
- Data protection by password.
- Selectable RS232 or RS485/422 serial line output
  - C protocol binary or ASCII character
  - MODBUS protocol RTU, or ASCII character

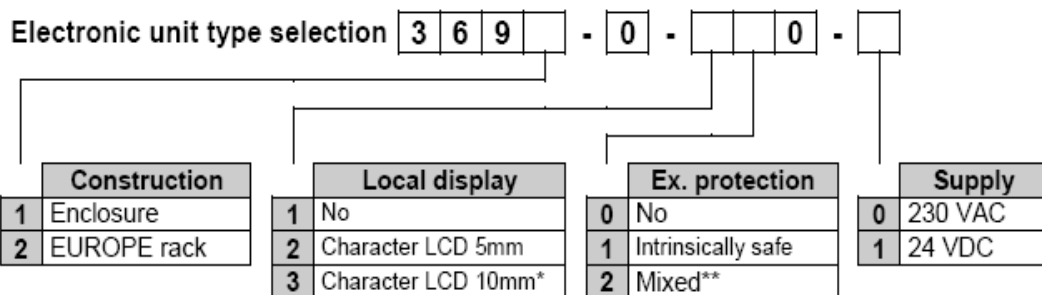

\*\* only in case of sensors K4000 and K6000

### Main features of the measuring system

The maximum error of the mass flow measurement within the specified measuring range consists of two components:  $\pm 0,2\%$  related to the measured value and  $\pm 0,05\%$  related to full scale

$$h = \pm 0,2 \pm \frac{5}{q} \quad (\%) \quad \text{where:} \quad q = \frac{\dot{m}}{\dot{m}_{\max}} * 100 \quad (\%)$$

- h** maximal error of measurement related to the measured value (%)  
**q** flow rate (%)  
 **$\dot{m}$**  massflow to be measured (kg/s)  
 **$\dot{m}_{\max}$**  maximal massflow (kg/s)

The length of the cable connecting the sensor and the signal processing unit is max. 300 m.

## Mechanical dimensions

### Sensor

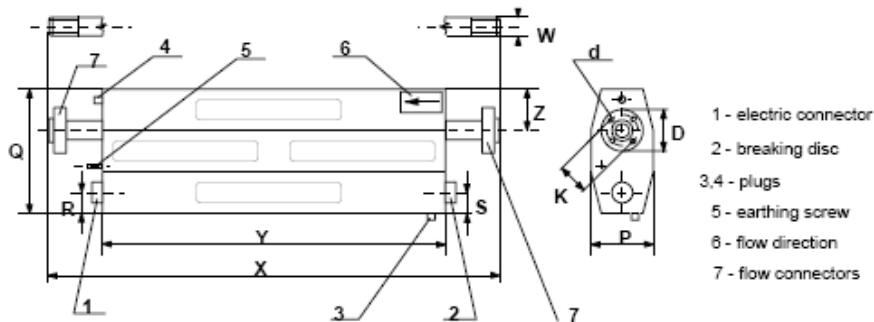

Type	X		Y	Z		P	Q	R	S	W thread	Flange						D N
	threaded	flanged		C code							DIN (40) bar			ANSI 150 LBS			
				1	3						D	K	d	D	K	d	
K20/K5	665	639	423	51	76	82	205,5	36	34	½"	95	65	4x14	89	60,5	4x16	15
K100	825	803	587	82	82	103	273,5	61	45	½"	95	65	4x14	89	60,5	4x16	15
K250	918	894	670	88	88	116	322	61	45	¾"	115	85	4x14	108	79	4x16	25
K500	1045	1013	777	61	77	127	370	61	63	1"	115	85	4x14	108	79	4x16	25
K2500	1219	1185	919	90	122	171	449	61	63	1½"	165	125	4x18	152	120,7	4x19	50
K2600	-	1185	919	128	-	233	449	61	63	-	200	160	8x18	-	-	-	80
K4000	-	1374	1112	122	-	271	541			-	200	160	8x18	-	-	-	80
K6000	-	1680	1320	378	-	327	820	60	96	-	200	160	8x18	-	-	-	80

### Signal processing units

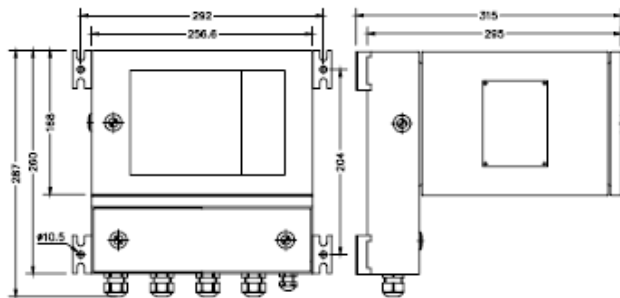

Enclosed construction

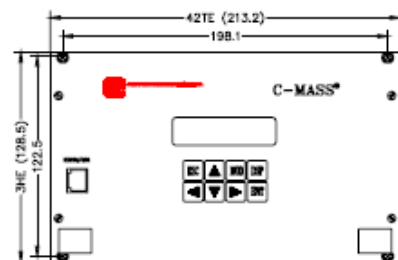

Rack construction (DIN 41494)

### Mechanical features of signal processing unit C-MASS®:

- Protection: enclosure IP54  
rack IP20
- Mass: enclosure 8 kg  
rack 4 kg
- Size: enclosure 260 x 256,6 x 295 mm  
rack 213 x 129 x 230 mm
- Cut-out for panel mounting of rack construction: 210x113 mm