

# VIBROTRAN

## Vibration transmitter

The vibration transmitter is designed for continuous monitoring of vibration intensity of various machines in the industry.

By means of the vibration sensor mounted on the bearing blocks, stators or bases of machines the vibration transmitter supplies direct current output signal proportional to the vibration level of the related assembly. The output signal thus obtained can be fed to the monitoring instrument mounted even at significant distance from the machine. As monitoring instrument e.g. a limit switch provided with indicating facility, recording instrument, or computer-based processing unit can be used.

### Specification

Type number

6 5 □ - 0 - □ □ □ - □ / X

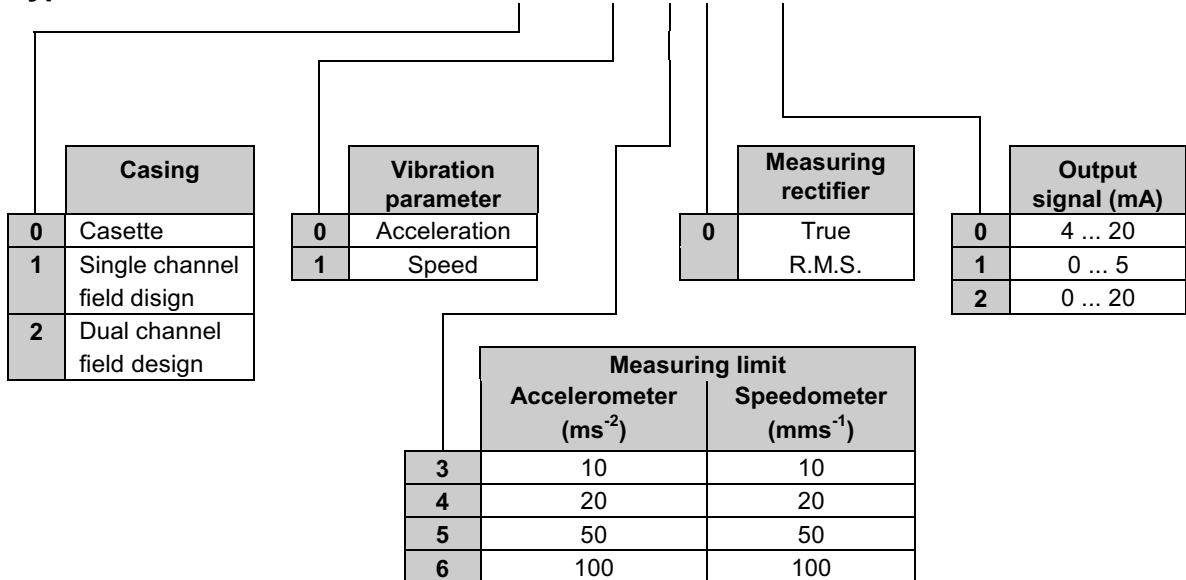

**X** – Special design

The sensing element of the vibration transmitter is made of ceramic material. Its operation is based on the physical phenomenon that electric charges are generated on the surface of certain materials (e.g. quartz) under the effect of material strength. The charge depends on the magnitude of force and the quality of the piezoelectric material.

In the vibration transmitter, the force will be generated by a so called seismic mass which exercises a force proportional to the acceleration on the piezoelectric material. The signal gained from the sensing element, which is proportional to the acceleration, is processed by the electronic unit of the transmitter.

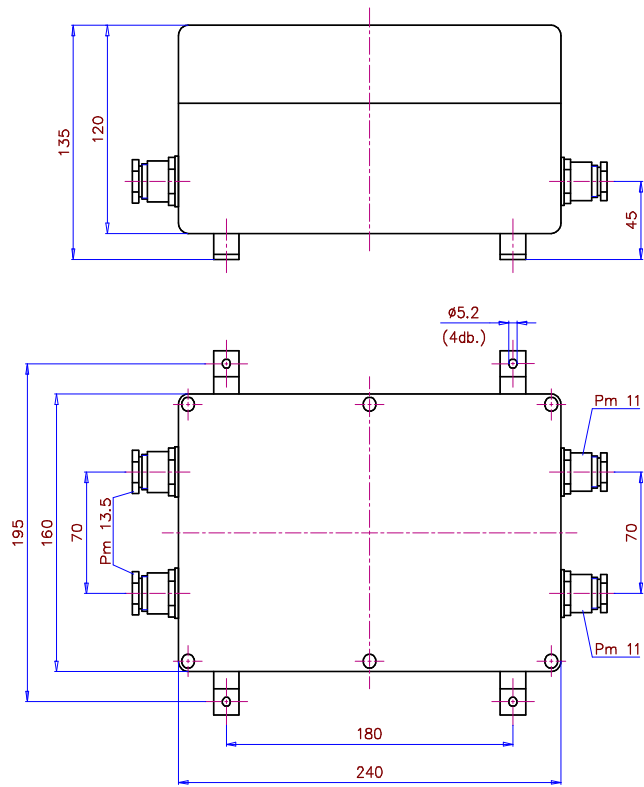

Outline drawing

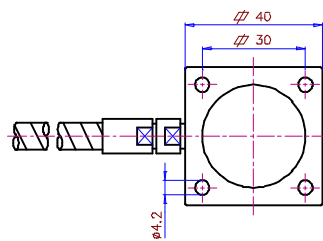
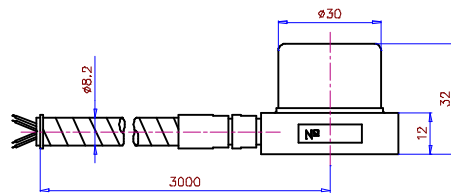

Outline drawing of the

sensing element