



APPLICATION

- Sensor with heat sink
- For remote measurement of temperature of steady and running liquids (gases and fluids), for which the properties of the heat sink of the sensor are suitable, up to nominal pressure PN 10, especially in the piping of small inner diameter or in places with lacking space.
 - As a pressure equipment of category III pursuant to the Decree of the Government 26/2003 Coll. (compliance assessment module B+D).
- Try sensor
- For measurement of temperature of the surface of warm water and other piping and other similar applications, e.g. for food packing machines.

DESCRIPTION

Sensor with heat sink
 The sensor consists of the sensor body with firmly connected cable. The body is provided with connecting screw-joint and heat sink, in which the probe is sealed.

Try sensor
 The sensor probe is sealed in cylindrical metal bushing. The sensor has no installation screw-joint; the type of installation depends on the specific application of the sensor.

For temperature measurement, a defined change of sensor resistance in dependence on the change of temperature of the measured conditions is used.

TECHNICAL DATA

The sensor is designed pursuant to ČSN EN 61010-1 as an electrical device of protection class III for the application in networks with category of overvoltage in installation II and pollution grade 2; the follow-up (assessment) device shall comply with Article 6.3 of the said standard.

- Measuring range:** -50 to 200 °C
- Electric strength** pursuant to ČSN EN 61010-1 Article 6.8.4: 500 V eff
- Electric insulation resistance** pursuant to ČSN IEC 751, Article 4.2.1: min. 100 MΩ, at 15 to 35°C, max. 80 % of relative humidity
- Nominal pressure of heat sink** pursuant to ČSN 13 0010: PN 10

- Coverage** pursuant to ČSN EN 60529: IP 65
- Operation position:** discretionary
- Weight of sensor with cable 1.5 m:**
 - with installation thread M10x1 approx. 100g
 - with installation thread M12 approx. 120 g
 - try sensor approx. 70 g
- Type of operation** continuous

- Applied materials:**
- sensor body and heat sink steel 1.4541
 - bushing of try sensor steel 1.4541 or brass with nickel galvanic coating
 - cable outlet Cu cores with insulation from fluoroplastic material, external insulation from silicon, shielding with Cu wire

OPERATION CONDITIONS

The environment is defined by the group of parameters and their severity grades IE 36 pursuant to ČSN EN 60721-3-3 and the following operation conditions.

- Temperature at cable outlet from the sensor:** permanently -50 to 180 °C
- Relative ambient humidity:** 10 to 100 % with condensation, with upper limit of water content 29 g H₂O/kg of dry air
- Atmospheric pressure:** 70 to 106 kPa
- Maximum speed of flow:**

water steam and air: 15 m/s
 water: 5 m/s

Vibrations:
 Frequency range 10 to 55 Hz
 Drift amplitude 0.35 mm
 Acceleration amplitude 49.0 ms⁻²

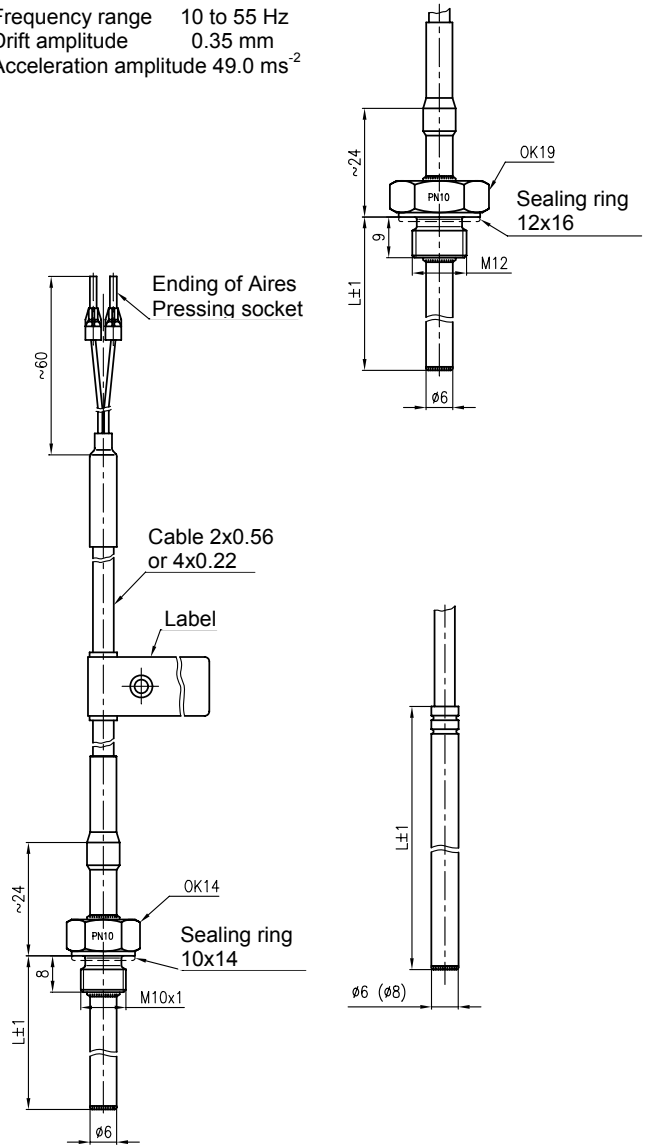

Sensor with heat sink

with thread M12

Try sensor

Connection scheme

with single measuring resistor
 in two-wire connection (Pt 100/B/2) in four-wire connection (Pt 100/ I4)



METROLOGICAL DATA

Sensor: single measuring resistor in connection pursuant to the connection scheme and table of designs

Platinum: Pt 100, Pt 500 or Pt 1000, $\alpha = 0.00385 [K^{-1}]$, tolerance class B (or A only for 4-wire) pursuant to ČSN IEC 751

Nickel: Ni 100, Ni 500 or Ni 1000, $\alpha = 0.00618 [K^{-1}]$ tolerance class B pursuant to DIN 43 760

Internal wiring resistance at 20 °C

2 x 0.56 mm²: 2×0.033 Ω/m

4 x 0.22 mm²: 4 ×0.087 Ω/m

Maximum current load of measuring resistor: 3 mA

Recommended measuring current:

Pt 100 or Ni100 1 mA

Pt 500 or Ni 500 0.5 mA

Pt 1000 or Ni 1000 0.3 mA

Calibration depth of immersion: 100 mm

Temperature response time pursuant to ČSN IEC 751 in whirling water (characteristic value): $\tau_{0,5}$ 8 s

DESIGNATION

Data on aluminium label connected to the cable

- Trade mark of the manufacturer
- Made in Czech Republic
- Type of resistance sensor, nominal value R_0 / tolerance class / configuration of internal wiring wires (tolerance class is not marked for Ni wires)
- Measuring range
- Coverage
- Production time code
- Mark CE 1015 (only for design with heat sink)

Data on heat sink hexagon

- Nominal pressure

CERTIFICATION

For design with heat sink

- Compliance certificate EC-112210
- Pressure equipment of category III pursuant to the Decree of the Government 26/2003 Coll. (compliance assessment module B+D), EC certificate of type test SZÚ Brno

DELIVERY

Unless agreed otherwise with the customer, each delivery includes

- Delivery note
- Sensor pursuant to the purchase order
- Sealing ring 10x14 for sensor with heat sink (or 12x16 for design with thread M12) pursuant to TPD 62-014-91
- Accompanying technical documentation in Czech:
 - o Product quality and completeness certificate, which also serves as the warranty certificate
 - o EC Compliance Certificate (for design with heat sink)

- o Calibration sheet (for calibrated design)
- o Product manual

If it is established in the purchase contract or agreed otherwise, the following documentation may be also delivered with the product

- o Copy of the EC certificate of type test pursuant to the Decree of the Government 26/2003 Coll. (for design with heat sink)
- o Copy of the Inspection Certificate 3.1 for the material of the heat sink of bushing of the try sensor with the casting number

DESIGN OF TEMPERATURE SENSORS

SPECIFICATIONS			ORDERING NUMBER				
			112 21	x	x	x	x
Measuring resistor	Platinum pursuant to ČSN IEC 751 tolerance class B or A*) (***)	Pt 100/B/2 or Pt 100/ /4 *)		1			
		Pt 500/B/2 *) or Pt 500/ /4 *)		2			
		Pt 1000/B/2 *) or Pt 1000/ /4 *)		3			
	Nickel pursuant to DIN 43760 tolerance class B (refer to the following table)	Ni 100/B/2 or Ni 100/ /4 *)		5			
		Ni 500/ B/2 *) or Ni 100/ /4 *)		6			
		Ni 1000/ B/2 *) or Ni 1000/ /4 *)		7			
Installation thread		M10x1			1		
		M12 *)			2		
Nominal length L [mm]		36				1	
		63 *)				2	
		80 *)				3	
		100 *)				4	
		Other (36 to 120 mm) *)				9	
Try sensor *)	Material 1.4541 or brass	Diameter / nominal length L	Ø 6 mm / 35 to 125 mm **)		3	5	
			Ø 8 mm / 25 to 125 mm **)		3	6	
Cable outlet length		1.5 m					1
		Other (min. 0.2 m, max. 3 m) *)					9

- *) Only as a special request on the basis of an agreement with the manufacturer
- ***) Measuring resistor in tolerance class A only in four-wire connection or in connection with auxiliary loop

TOLERANCE CLASS OF NICKEL MEASURING RESISTORS PURSUANT TO DIN 43760

Class	Tolerance [°C (K)]		ZPA designation
	t < 0 °C	t > 0 °C	
DIN 43760	0.4 + 0.028 t	0.4 + 0.007 t	B

*) Only as a special request on the basis of an agreement with the manufacturer

ORDERING

The purchase order shall specify

- Name
- Product ordering number
- If calibration is required and in what temperature points
- Other (special) requirements
- Number of pieces

PACKING

Both the sensors and accessories are delivered in a packing ensuring resistance to the impact of thermal effects and mechanical effects pursuant to controlled packing regulations.

PURCHASE ORDER EXAMPLE

Standard design

1. Resistance temperature sensor with heat sink PN 10, with cable outlet 112 211 111 - 15 pcs

Special request:

1. Resistance temperature sensor with heat sink PN 10, with cable outlet 112 212 149 nominal length 100 mm, cable length 2.5 m - 6 pcs
2. Try resistance temperature sensor, with cable outlet 112 211 351 nominal length 50 mm - 6 pcs

TRANSPORT

The converters may be transported on conditions corresponding to the set of combinations of classes IE 21 pursuant to ČSN EN 60721-3-2 (i.e. by airplanes and trucks, in premises that are ventilated and protected against atmospheric conditions).

STORAGE

The sensors may be stored on conditions corresponding to the set of combinations of classes IE 11 pursuant to ČSN EN 60721-3-1 (i.e. in places with continuous temperature control from 5 to 40 °C and with humidity from 5 to 85%, without a special threat of an attack with biological agents, with vibrations of small significance and not situated close to sources of dust and sand.)

CALIBRATION

It is realized pursuant to TPM 3342-94 and in compliance with ČSN IEC 751, usually in three temperature points distributed evenly within the operation range of the sensor or in the points according to the requirement of the customer. Calibration sheet with measured data is issued for calibrated sensors.

INSTALLATION AND CONNECTION**INSTALLATION OF SENSOR WITH HEAT SINK**

Put the enclosed sealing ring on the sensor heat sink in advance. Then connect the sensor by screwing it into the weld-on piece on the piping (technological equipment) or into the relevant hole with a thread. During the installation, torque of 40 Nm is recommended.

With respect to maintaining metrological properties and the longest possible service life, it is not recommended to install the sensors in places with high turbulence of the medium, which is caused e.g. by a rapid transition from a small diameter of the piping to a larger one (when failing to comply with the required shape and dimensions of diffuser behind the flow meter). Recommended distance of the temperature sensor from the installation flange of the flow meter is min. 1 m.

INSTALLATION OF TRY SENSOR

Connect the try sensor to the piping surface e.g. by wrapping with a metal tightening stripe or a special try device. We recommend ensuring due heat insulation of the connected sensor. One of many other ways of the installation is the insertion of the try sensor into the bore in the body (e.g. of a food packing machine).

ELECTRICAL CONNECTION

The electrical connection may be only realized by qualified workers pursuant to § 5 of the Decree 50/1978 Coll.

**WARNING**

The sensor cable shall be protected against the effect of oil substances and organic solvents!

COMMISSIONING

After the sensor installation and connection of the follow-up (evaluation) device to the supply voltage, the equipment is prepared for operation.

OPERATION AND MAINTENANCE

The sensor does not require any operation and maintenance.

SPARE PARTS

The sensor design does not require any delivery of spare parts.

WARRANTY

Pursuant to § 429 of the Commercial Code and the provisions of § 620 (2) of the Civil Code, the manufacturer warrants for technical and operation parameters of the product specified in the manual. The warranty period is 24 months from the receiving of the product by the customer, unless established otherwise in the contract. The rejection of defects shall be enforced in writing at the manufacturer within the warranty period. The rejecting side shall identify the product name, ordering and manufacturing numbers, date of issue and number of the delivery note, clear description of the occurring defect and the subject of the claim. If the rejecting side is invited to send the device for repair, it shall do so in the original package of the manufacturer and/or in another package ensuring safe transport.

The warranty shall not apply to defects caused by unauthorized intervention into the device, its forced mechanical damage or failure to comply with operation conditions of the product and the product manual.

REPAIRS

The sensor cannot be dismantled and, therefore, is not repaired.

DISABLING AND LIQUIDATION

They shall be realized in compliance with the Waste Act No. 106/2005 Coll.

Both the product and its package do not include any parts that could impact the environment.

Products that are withdrawn from operation, including their packages (with the exception of products marked as electrical equipment for the purposes of return withdrawal and selected salvage of electrical waste), can be disposed of to the sorted or unsorted waste pursuant to the type of waste.

The manufacturer realizes free return withdrawal of marked electrical equipment (from 13.8.2005) from the consumer and points out the danger connected with their illegal disposal.

The package of the sensor can be recycled completely.

Metal parts of the products are recycled, non-recyclable plastic materials and electrical waste shall be disposed of in compliance with the aforesaid Act.

**MMG Műszerszerviz Kft.**

1036 Budapest, Dereglye u. 1.,

Tel/fax: 204-2252, Tel:203-7443

Web: www.mmg.hu, E-mail: info@mmg.hu