



# MMG Műszerszerviz Kft.

1036 Budapest, Dereglye u. 1.,  
 Tel/fax: 204-2252, Tel:203-7443  
 Web: [www.mmg.hu](http://www.mmg.hu), E-mail: [info@mmg.hu](mailto:info@mmg.hu)

FOR DESIGNS WITH CONVERTER A MANUAL IS ENCLOSED TO THE RELEVANT CONVERTER

## APPLICATION

- For exact remote measurement of temperature of steady and running liquids (gases and fluids), for which the properties of the heat sink of the sensor selected by the customer are suitable; measurement may be realized up to temperature determined by heat sink resistance (max. 600°C) and nominal pressure PN 160
- For explosive environment in premises Zone 2, Zone 1 and Zone 0 pursuant to ČSN EN 60079-10 when using the converter Ex ia or in case of connection to Ex ia circuit
- As pressure equipment of category III pursuant to the Decree of the Government 26/2003 Coll. (compliance assessment module B+D)
- In a set with control or diagnostic systems for process monitoring
- In design with converter for transfer of resistance sensor signal to unified output signal 4 to 20 mA or digital signal (converter with HART protocol)

The sensors with converter are rated products pursuant to the Act No. 22/1997 Coll. and Declaration of Conformity **EC-232000** is issued for them.

## DESCRIPTION

The sensor consists of a replaceable measuring insert with flange and ceramic terminal board or installed two-wire converter (insulated or non-insulated, even in design Ex i) and protective armature consisting of a head and a heat sink with an adapter and connecting screw union. The head is provided with a lid and a cable outlet for the connecting wiring. The terminal board (of the converter) of the sensor is accessible after tilting away the lid of the head, which is connected with one screw. The sensor with converter in the Ex ia design is provided with an external clamp and an internal clamp on the head for the connection of the grounding wire or wire for mutual interconnection.

The converter is installed either directly on the flange of the measuring insert or in the lid of the head.

The sensor with converter is supplied from an external source. The installed converter is pre-set to the required range at the sensor manufacturer.

To measure temperature, a defined change of sensor resistance in dependence on the change of temperature of the measured environment is used.

## TECHNICAL DATA

The sensor dimensions are based on the original ČSN 25 8301. The sensor is designed pursuant to ČSN EN 61140 ed.2 as an electric equipment of protection class III for the application in networks with category of overvoltage in installation II and pollution grade 2 pursuant to ČSN EN 61010-1; the follow-up (evaluation) device shall comply with Article 6.3 of the said standard.

### Measuring range:

The sensor with standard adapter  $L_n = 150$  mm  
 -70 to 600 °C

The sensor with shortened adapter  $L_n \text{ min} = 80$  mm  
 -70 to 250 °C

The upper limit of the range of measurement is limited by resistance of the material of the applied heat sink.

Measuring range of the sensor with converter is established by the range of the selected converter

**Electric strength** pursuant to ČSN EN 61010-1, Article 6.8.4: 500 V eff

(only measuring insert without converter or design with insulated converter)

**Electric insulation resistance** pursuant to ČSN IEC 751, Article 4.2.1:

min. 100 M $\Omega$ , at 15 to 35°C, max. 80 % rel. humidity

### Power supply of converter:

DC 24 V from source SELV, e.g. INAP 16 and INAP 901

**Other data of converter:** refer to the enclosed manual

**Ingress protection** pursuant to ČSN EN 60529: IP65

**Nominal pressure of heat sink** pursuant to ČSN 13 0010: PN 160

### Operation position:

discretionary; the outlet shall not be situated upwards

**Type of operation:** continuous

### Sensor weight:

with ball head (Al alloy), adapter 150 mm and nominal length 250 mm  
 approx. 1.06 kg

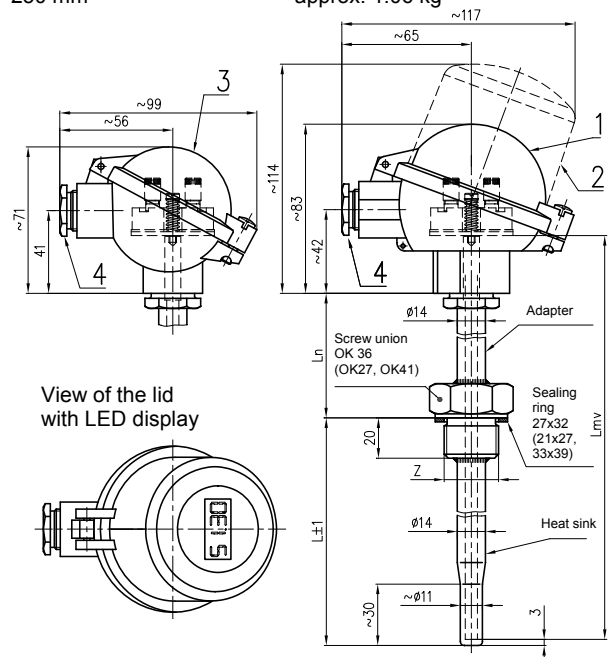

- 1 - Ball head (Al alloy)  
 (for the converter Ex i with external and internal clamps) or plastic ball head  
 (it cannot be used for the converter Ex i)
  - 2 - Ball head with increased lid (alloy Al)  
 without display for the converter in the lid or with display  
 (for the converter Ex i with external and internal clamps)
  - 3 - Small ball head (Al alloy)  
 (only for the terminal board or the converter INPAL 420)
  - 4 - Cable outlet M20x1.5
- L Nominal length  
 $L_n$  Length of adapter  
 $L_{mv}$  Length of measuring insert  
 Z Connecting thread of adapter of the sensor
- |                                    |      |
|------------------------------------|------|
| G $\frac{1}{2}$ , M20x1.5          | OK27 |
| G $\frac{3}{4}$ , M27x2, 3/4-14NPT | OK36 |
| G1                                 | OK41 |

### Applied materials:

Heat sink	steel 1.4541 or 1.4571
Stem tube of measuring insert	steel 1.4541
Adapter	steel 1.4541
Head	aluminium alloy painted with polyester paint or plastic PPO (phenyl polyoxide)

Sealing of lid of the head	oil resistant rubber
Internal wiring	Cu
Head terminals of the terminal board	brass with Ni surface
Connecting elements of the sensor	stainless steel

**OPERATION CONDITIONS**

The environment is defined by the group of parameters and their severity grades IE 36 pursuant to ČSN EN 60721-3-3 and the following operation conditions.

**Ambient temperature for head and outlet of the sensor:**

- For design without converter -50 °C to 120 °C
- For design with converter pursuant to the type of the converter (refer to the enclosed converter manual)
- For design with converter and display -20 °C to 70 °C

**Vibrations:**

Nominal length [mm]	100	160	250	400	630
Frequency range [Hz]	10 to 500				
Drift amplitude [mm]	0.2	0.2	0.15	0.1	0.1
Acceleration amplitude [ms <sup>-2</sup> ]	29.4	29.4	19.6	19.6	19.6

**Relative ambient humidity:**

10 to 100 % with condensation, with upper limit of water content 29 g H<sub>2</sub>O/kg of dry air

**Atmospheric pressure:** 70 to 106 kPa

**Maximum speed of flow of liquids:**

Maximum speed of flow [m/s]	Nominal length [mm]				
	100	160	250	400	630
Water steam and air	50	25	8	2.5	1
Water	5	3	3	1.5	0.2

**Resistance of material of the head PPO (phenyl polyoxide):**

Kerosene	partially resistant
Diesel oil	resistant
Benzene	partially resistant
Animal and vegetable oil	resistant
Weak hydroxides	
Strong hydroxides	
Weak acids	
Strong acids	
Sea water	partially resistant
Trichloroethylene	

**Resistance of lid sealing material (oil resistant rubber):**

Spirit	resistant
Ether	
Benzole	
Petrol	
Ester	
Animal and vegetable oil	
Mineral oil	
Diesel oil	
Weak alkali hydroxides	
Strong alkali hydroxides	
Weak acids	resistant
Strong acids	not resistant
Sea water	resistant
Trichloroethylene	partially resistant
Hot water	

**METROLOGICAL DATA**

**Sensing probe:** measuring resistor Pt 100 in connection pursuant to scheme and table of designs,  $\alpha = 0.00385 [K^{-1}]$ , tolerance class A or B pursuant to ČSN IEC 751

**Internal wiring resistance at 20 °C:** 0.1 /m

The calculated resistance value of internal wiring of the design without converter is specified on the label of the measuring insert.

**Maximum current load of measuring resistor:** 3 mA

**Recommended measuring current:** 1 mA

**Output signal of the converter** (linear with measured temperature): 4 to 20 mA (+ digital for HART protocol)

**Calibration depth of immersion of the measuring insert of the sensor**

- for temperature points within range -70 to 250°C: 200 mm (min. 160 mm)
- for temperature points above 250°C: 300 mm (min. 260 mm)

The distance of flange of the measuring insert from the level of medium in the calibration bath shall be at least 40 mm at temperatures to 250°C and min. 70 mm at temperatures above 250°C.

**Temperature response time** pursuant to ČSN IEC 751 in

whirling water (characteristic value):	0.5	29 s
	0.9	95 s

**DESIGNATION:**

**Data on label of head**

- Trademark of the manufacturer
- Made in Czech Republic
- Type of resistance sensor, nominal value R<sub>0</sub> / tolerance class / configuration of wires of internal wiring \*)
- Measuring range or set-up converter range
- Product ordering number
- Ingress Protection
- Manufacturing number
- Output signal 4 to 20 mA (design with converter)
- Ambient temperature
- Mark of non-explosiveness and number of the EC Type Examination Certificate (for design with converter Ex i)
- CE mark 1015
- CE mark with identification number of the notified person (for design with converter Ex i)

\*) Configuration of wires of internal wiring is not specified for the converter

**Data on label of measuring insert**

- Trade mark
- Sensor type, nominal value R<sub>0</sub> / tolerance class / configuration of wires of internal wiring \*)
- Manufacturing number
- Resistance value of internal wiring (for design without converter)

\*) Configuration of wires of internal wiring is not specified for the converter

**Data on label of converter**

- Sensor type
- Pre-set temperature range

**DELIVERY**

Unless agreed otherwise with the customer, each delivery includes

- Delivery note
- Sensor pursuant to the purchase order
- Sealing ring
  - o 21x27 TPD 62-014-91 for thread G½ and M20x1.5
  - o Cu 27 x 32 x1.5 (ČSN 02 9310.2) for thread M27 x 2 and G¾
  - o Cu 33 x 39 x 2 (ČSN 02 9310.2) for thread G1 (for thread 3/4-14NPT the sealing ring is not delivered)
- Suitable weld-on pieces ordered separately pursuant to the catalogue of accessories, type 991
- Optional accessories to the sensor with programmable converter
  - o Configuration (parameterization) programme pursuant to the required converter
  - o Communication modem (for serial port RS 232C) pursuant to the required converter
- Accompanying technical documentation in Czech
  - o Product quality and completeness certificate, which also serves as the warranty certificate
  - o EC Declaration of Conformity for design with converter Ex i
  - o Calibration sheet (for uncertified calibrated design)
  - o Product manual

If it is established in the purchase contract or agreed otherwise, the following documentation can be also delivered with the product

- Copy of the Inspection Certificate 3.1 for material of stem tube and heat sink with the casting number

- Copy of the EC Type Examination Certificate pursuant to the Decree of the Government 23/2003 Coll. for design with converter Ex i
- Copy of the EC Type Examination Certificate pursuant to the Decree of the Government 26/2003 Coll.

#### **ORDERING TEMPERATURE SENSORS**

The purchase order shall specify

- Name
- Product ordering number
- Measuring range
- If calibration is required and in what temperature points
- If the delivery of weld-on piece pursuant to the type 991 is required for the sensor as accessories
- If optional accessories to the sensor with programmable converter are required
- Other (special) requirements
- Number of pieces

Behind the ordering number specified pursuant to the table 1, the customer shall identify the required range of measured

temperature (i.e. lower and upper temperature limits in °C) and, as the case may be, other non-standard required parameters for converter configuration (e.g. indication of sensor tripping, dampening, required designation - tagging etc.).

#### **PURCHASE ORDER EXAMPLE**

##### **Standard design:**

Resistance temperature sensor with heat sink ČSN  
Without converter  
242 412 331 1B/J4  
Range -70 to 600°C  
6 pcs

##### **Special request:**

Resistance temperature sensor with heat sink ČSN  
With converter  
242 912 231 1B/18  
Nominal length L 380 mm, range 0 to 100°C  
6 pcs

TABLE 1 - DESIGN OF TEMPERATURE SENSORS WITH HEAT SINK ČSN TYPE 242

SPECIFICATIONS					ORDERING NUMBER																																	
					242	x	x	x	x	x	1	x	x	/xxxxxx	/xxx																							
Nominal length L [mm]	100	Length of adapter L <sub>n</sub> [mm]	150	Length of measuring insert L <sub>mv</sub> [mm]	280	1	1																															
	160				2																																	
	250				3																																	
	400				4																																	
	630				5																																	
	Other (min. 75) *)				9																																	
Nominal length L [mm]	100	Length of adapter L <sub>n</sub> [mm]	80	Length of measuring insert L <sub>mv</sub> [mm]	210	1	2																															
	160				2																																	
	250				3																																	
	400				4																																	
	630				5																																	
	Other (min. 75) *)				9																																	
Length of adapter	150 mm					1																																
	80 mm					2																																
	Other **)*)					9																																
Heat sink material	1.4571																																					
	1.4541																																					
	Other *)																																					
Connecting thread	G1/2																																					
	G1																																					
	M27x2																																					
	G3/4																																					
	3/4-14 NPT																																					
	M20x1.5																																					
Sensor head	Ball (Al alloy) (with converter Ex i with external and internal clamps)																																					
	Plastic ball (it cannot be used with converter Ex i)																																					
	Ball head with increased lid (Al alloy) without display with converter in the lid or with display (with converter Ex i with external and internal clamps)																																					
	Small ball (Al alloy) (only for the terminal board and the converters INPAL 420, APAQ-HRF, TH 100, MINIPAQ-HLP)																																					
	other *)																																					
Measuring resistor (sensing probe)	Pt100																																					
Tolerance class	A																																					
	B																																					
Connection of the terminal board	Single - four-wire (1xPt100/ /4)																																					
	Double- two-wire (2xPt100/B/2)																																					
	Double- three-wire (2xPt100/ /3)																																					
Converter type		Galvanic separation		Ex	Range [°C]																																	
Analogue	INPAL 420				-50 to 50																																	
					-30 to 70																																	
					0 to 50																																	
					0 to 100																																	
					0 to 150																																	
					0 to 200																																	
					0 to 250																																	
					0 to 400																																	
APAQ-HRF																																						
APAQ-HRFX																																						
Programmable																																						
																				TH 100																		
																				TH 100-ex																		
																				TH 200																		
																				TH 200-ex																		
																				IPAQ-H																		
IPAQ-HX																																						
MINIPAQ-HLP																																						
HART protocol																																						
																				TH 300																		
																				TH 300-ex																		
																				MESO-H																		
																				MESO-HX																		
																				248 HA NA																		
																				248 HA I1																		
																				644 HA NA																		
644 HA I1																																						
Other *)																																						
Without converter (for installation of the converter by the customer)																																						
LED display to loop 4-20mA (only with converter, with the exception of converter 644 HA)																																						
LED display																																						
Standard design																																						

\*) Only as a special request after an agreement with the manufacturer  
 \*\*) In case of adapter length below 150 mm (minimum 80 mm), the temperature range is decreased to -70 to 250 °C

## ORDERING WELD-ON PIECES

The purchase order shall specify:

- Name
- Ordering number of weld-on piece
- Number of pieces

## ORDERING NUMBERS OF WELD-ON PIECES, type 991

Direct weld-on piece - 991 NVP4 M27 13 (material 11 353.0)  
 - 991 NVP4 M27 72 (material 1.4541)  
 Angular weld-on piece - 991 NVS4 M27 13 (material 11 353.0)  
 - 991 NVS4 M27 72 (material 1.4541)

## PACKING

Both sensors and accessories are delivered in a packing ensuring resistance to the impact of thermal effects and mechanical effects pursuant to controlled packing regulations.

## TRANSPORT

The sensors may be transported on conditions corresponding to the set of combinations of classes IE 21 pursuant to ČSN EN 60721-3-2 (i.e. by airplanes and trucks, in premises that are ventilated and protected against atmospheric effects).

## STORAGE

The sensors may be stored on conditions corresponding to the set of combinations of classes IE 12 pursuant to ČSN EN 60721-3-1, but with ambient temperature from -20 to 70 °C (i.e. in places where temperature and humidity are not regulated, with a threat of occurrence of condensation, dripping water and formation of ice, without a special threat of an attack with biological agents, with vibrations of small significance and not situated close to sources of dust and sand).

## CERTIFICATION

- Pressure equipment pursuant to the Decree of the Government 26/2003 Coll., EC Type Examination Certificate SZÚ Brno
- Non-explosiveness Ex i, EC Type Examination Certificate pursuant to the Decree of the Government 23/2003 Coll., (pursuant to the type of converter)

## RELIABILITY

Reliability indicators in operation conditions and ambient conditions specified herein

- Mean time of operation between failures 96 000 hours  
(inf. value)
- Expected service life 10 years

## CALIBRATION

It is realized pursuant to TPM 3342-94 and in compliance with ČSN IEC 751, usually in three temperature points evenly distributed within the operation range of the sensor or in the points according to the requirement of the customer. Calibration sheets with measured data are issued for calibrated sensors.

## INSTALLATION AND CONNECTION SENSOR INSTALLATION

Install the sensors by screwing into the weld-on piece on the piping (technological equipment). Before the installation, put on the enclosed sealing ring in advance (for thread 3/4-14NPT, the sealing ring is not used). During the installation, torque of 150 Nm is recommended; 70 Nm for thread 3/4-14NPT.

A proposal of securing the heat sink of the temperature sensors Ex d for nominal lengths exceeding 630 m is in figure 1; examples of installation of direct and angular weld-on pieces are in figure 2.

With respect to maintaining metrological properties and the longest possible service life, it is not recommended to install the sensors in places with high turbulence of the medium, which is caused e.g. by a rapid transition from a small diameter of the piping to a larger one (when failing to comply with the required shape and dimensions of diffuser behind the flow meter), etc. Recommended distance of the temperature

sensor from the installation flange of the flow meter is min. 1 m.

## ELECTRICAL CONNECTION

The electrical connection may be only realized by qualified workers pursuant to § 5 of the Decree 50/1978 Coll.

The terminal board of the sensor (converter) is accessible after tilting the lid of the head, which is connected with one screw.

Connect the evaluation devices to the sensor with a non-armoured cable with double insulation with outer diameter from 5 to 8 mm (internal wires with Cu core with the cross section from 0.5 to 1.5 mm<sup>2</sup>. Seal the cable outlet adequately



### WARNING

**Do not use independent wires without jacket for electrical connection. To ensure the ingress protection grade in the outlet, the connecting cable shall have circular cross-section. Temperature resistance of the cable shall comply with the ambient temperature!**

The cable insulation shall have chemical and mechanical resistance in compliance with the conditions, in which the cable will be installed. It is recommended supporting the cable along its length between the sensor and the follow-up device. In the environment with interfering signals, use shielded cable in the power supply circuit. Shielding may be only grounded (earthed) in one point. The cable should not be placed together with power cables.

In case of the sensor with HART protocol converter, the maximum length of wiring is defined by the arrangement of wires of the connecting cable. The total length of wiring may be up to 1500 m. It requires a twisted two-wire with shared shielding with the cross section of the core min. 0.5 mm<sup>2</sup>. HART communicator is connected to the supply loop of the sensor with converter pursuant to Figure 3. To achieve reliable communication, total load resistor of min. 250 shall be in the circuit of the output loop.

## INSTALLATION OF THE SENSOR WITH CONVERTER Ex i IN CONDITIONS WITH EXPLOSIVE GASEOUS ATMOSPHERE

The sensor installation in conditions with explosive gaseous atmosphere shall comply with the requirements of ČSN EN 60079-14 ed. 2.



### WARNING



**Ex i parameters shall be complied with pursuant to the enclosed converter manual.**

**To ensure safety, an intrinsic safe source shall be always used pursuant to the converter manual, e.g. INAP 901 ordering number 901 000 101.**

**Surface temperature of the converter may not exceed maximum surface temperature for that particular temperature class.**

**Programmable converter may not be connected to a computer or a HART communicator if the converter is located in explosive environment.**

For installations in dangerous areas, mutual interconnection is required (bringing to the same potential). To achieve it, clamps on the sensor head can be used.

The sensor need not be connected to the system of mutual connection independently if it is installed firmly and has metal interconnection with the structural parts or the piping, which is connected to the system of mutual connection.

## HEAD OF THE SENSOR WITH CLAMPS

for the sensor with converter Ex i

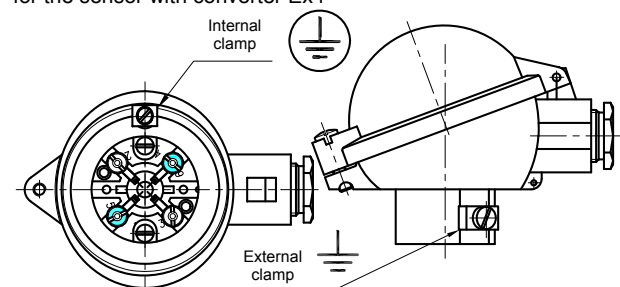

**Maximum cross-section of wire for connection to external and internal clamps:**

Internal clamp: stranded wire 1.5 mm<sup>2</sup>, full wire 2.5 mm<sup>2</sup>  
 External clamp: stranded wire 4.0 mm<sup>2</sup>, full wire 6.0 mm<sup>2</sup>  
 If stranded wires are used for the interconnection, they shall be protected against fraying with pressing hollow.

**COMMISSIONING**

After the sensor installation, including closing the fixed closure, and connection of the follow-up (evaluation) device to the supply voltage (and the settlement period of the converter), the equipment is prepared for operation.

**OPERATION AND MAINTENANCE**

The sensor does not require any operation and maintenance.

**SENSOR UNINSTALLATION**

Disconnect the sensor from the supply source.  
 The terminal board of the sensor (converter) is accessible after tilting of the lid of the head that is connected with one screw.  
 Measuring insert of the sensor can be replaced and is removed from the head after disconnecting the cable by releasing two screws.  
 If the sensor is connected to the system of interconnection, it is necessary to release the wire for mutual interconnection from the terminal on the head of the sensor before the total uninstallation of the sensor.  
 Screw the sensor from the heat sink; torque is approx. 70 Nm.  
 While releasing the screw union of the sensor, the heat sink may never be released.

**SPARE PARTS**

Spare parts shall be delivered by the manufacturer.  
 Relevant measuring inserts can be ordered pursuant to the following table:

SPECIFICATIONS		ORDERING NUMBER					
		MV240	/x xx /	1	x	x	/xxxx
Length of measuring insert [mm]			pu rs. to ta ble 1	1			
Sensing probe	Pt100				1		
Tolerance class	A					A	
	B					B	
Connection of the terminal board or converter	Pt100/ /4						/J4
	2xPt100/B/2						/D2
	2xPt100//3						/D3
	converter pursuant to tab. 1						/ convert er

**EXAMPLE OF PURCHASE ORDER OF MEASURING INSERT**

Resistance measuring insert without converter  
 240 /430/ 11B/J4 - 6 pcs

**WARRANTY**

Pursuant to Section 429 of the Commercial Code and the provisions of Section 620 (2) of the Civil Code, the manufacturer warrants for technical and operation parameters of the product specified in the manual. The warranty period is 24 months from the receiving of the product by the customer, unless established otherwise in the contract. Rejection of defects shall be enforced in writing at the manufacturer within the warranty period. The rejecting side shall identify the product name, ordering and manufacturing numbers, date of

issue and number of the delivery note, clear description of the occurring defect and the subject of the claim. If the rejecting side is invited to send the device for repair, it shall do so in the original package of the manufacturer and/or in another package ensuring safe transport.

The warranty shall not apply to defects caused by unauthorized intervention into the device, its forced mechanical damage or failure to comply with operation conditions of the product and the product manual.

**REPAIRS**

The sensors shall be repaired by the manufacturer. They shall be sent for repair in the original or equal package without accessories.

**DISABLING AND LIQUIDATION**

They shall be realized in compliance with the Waste Act 106/2005 Coll.

The product and its package do not include any parts that could impact the environment.

The products that are withdrawn from operation, including their packages (with the exception of products marked as electrical equipment for the purposes of return withdrawal and separate salvage of electrical waste), may be disposed of to sorted or unsorted waste pursuant to the type of waste.

The manufacturer realizes free return withdrawal of marked electrical equipment (from 13.8.2005) from the consumer and points out the danger connected with their illegal disposal.

The package of the sensor can be recycled completely. Metal parts of the products are recycled, non-recyclable plastic materials and electrical waste shall be disposed of in compliance with the aforesaid Act.

**FIGURE 1 - PROPOSAL OF SECURING HEAT SINK OF TEMPERATURE SENSORS** (for nominal lengths exceeding 630 mm)

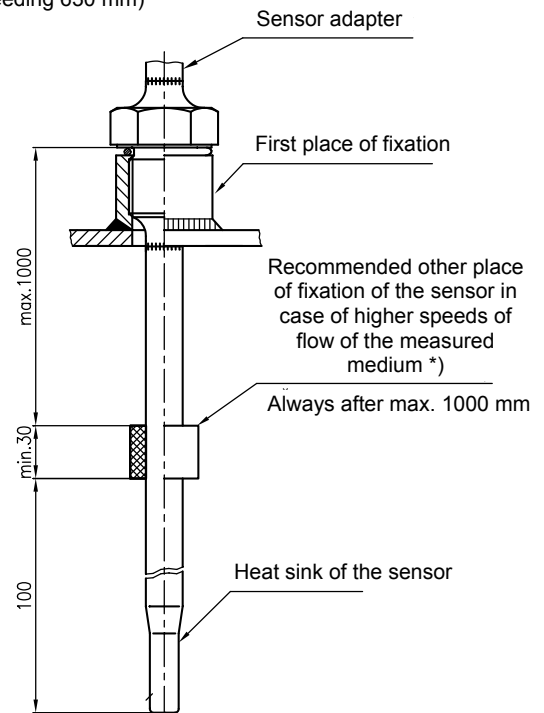

\*) In case of flow of the measured medium, the heat sinks are stressed with dynamic effects of the flowing medium and this stress depends on the speed of flow, physical properties of the measured medium and immersion length of the heat sink. If the occurrence of such dynamic effects can be expected, it is recommended to realize further fixation of the sensor of the heat sink pursuant to the above mentioned proposal.

**FIGURE 2 - EXAMPLES OF INSTALLATION OF DIRECT AND ANGULAR WELD-ON PIECES PURSUANT TO ČSN EN 1434-2**

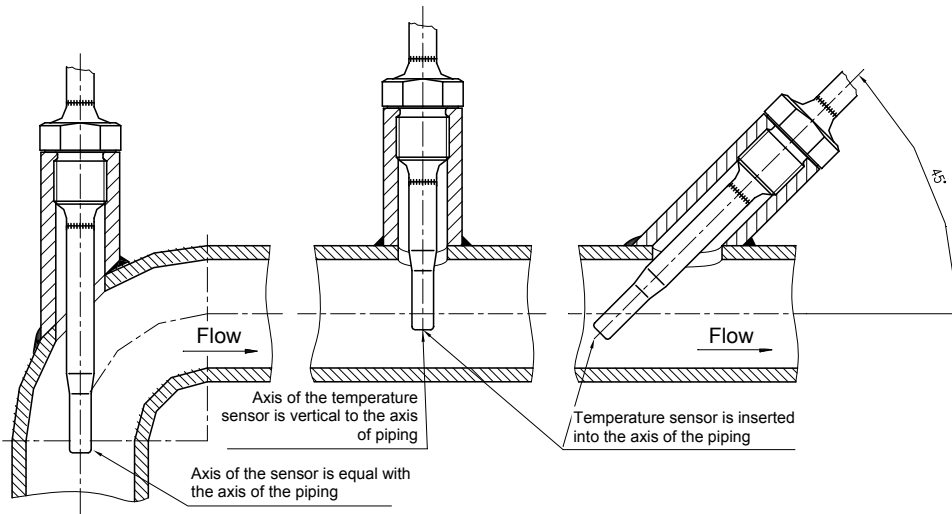

**WARNING**

- When using the sensor with an angular weld-on piece, locate the sensor with heat sink at an angle against the direction of flow
- The sensor may not touch the opposite side of the piping
- It is also advantageous to use the temperature sensors in the piping elbow. In such a case, locate the sensor with the heat sink against the direction of flow so that the measured medium flows around evenly

**FIGURE 3 – SCHEME OF CONNECTION OF TEMPERATURE SENSORS**  
without converter                      with converter                      with converter  
with HART protocol

With single measuring resistor in four-wire connection (Pt 100/ /4)

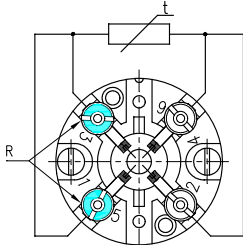

With double measuring resistor in two-wire connection (2 × Pt 100/B/2)

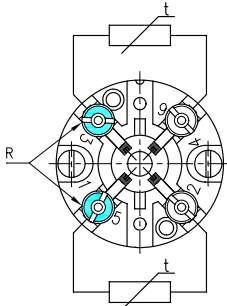

With double measuring resistor in three-wire connection (2 × Pt 100/ /3)

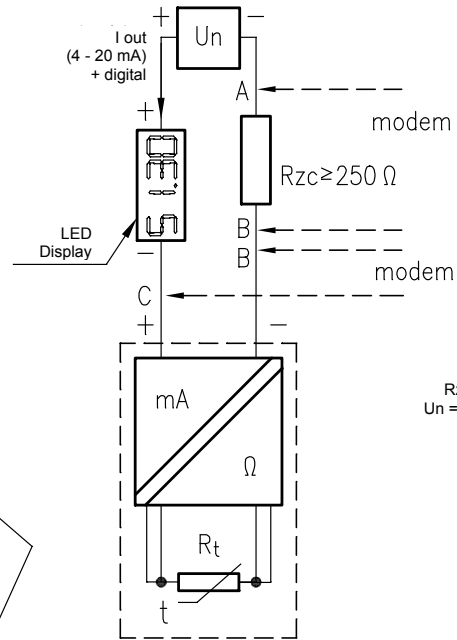
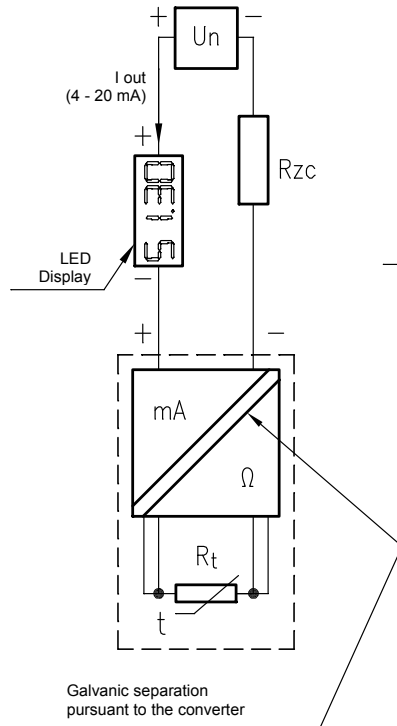
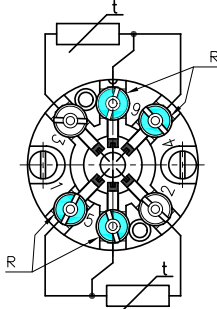

A-B and B-C options of connection of the control unit (HART modem, HART communicator)

Rzc = Total load resistance  
Un = Supply voltage of source

FIGURE 4 - EXAMPLE OF OPERATION CONNECTION OF TEMPERATURE SENSOR WITH CONVERTER IN LOOP 4 - 20 mA

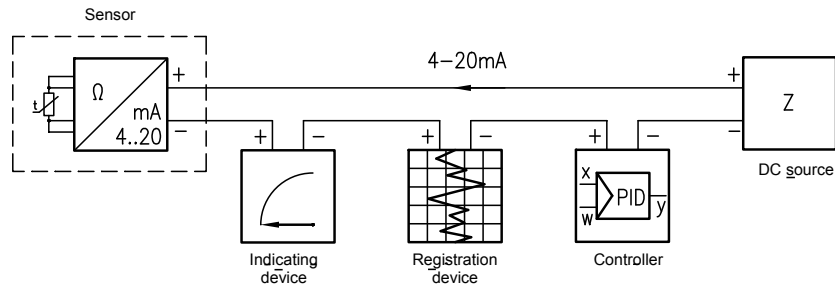

**MMG Műszerszerviz Kft.**  
 1036 Budapest, Dereglye u. 1.,  
 Tel/fax: 204-2252, Tel:203-7443  
 Web: [www.mmg.hu](http://www.mmg.hu), E-mail: info@mmg.hu